



2/2-way Angle-Seat Valve with stainless steel design for medium up to +185 °C, DN 15-65

- High flow rates
- High cycle life
- Flow optimised body in stainless steel
- Deliverable with flow direction below or above seat
- Clean design for optimal use in hygienic environment
- Suitable for steam up to 10 bar(g)

Type 2100 threaded can be combined with...



Type 8691
Control Head



Type 8695
Control Head



Type 8690
Pneumatic Control Unit



Type 8697
Pneumatic Control Unit



Type 8619
MultiCELL Transmitter/Controller



Type 8222
Conductivity transmitter

In line with Bürkert's philosophy for modular valves and sensors the construction of the 2100 angle-seat valve fulfils tough criteria for process environments. Unrivalled cycle life and sealing integrity is guaranteed by the proven self adjusting spindle packing with V-seals.



The design enables the easy integration of automation modules whether they are electrical/optical position feedback, pneumatic control units, an integrated fieldbus interface.

The fully integrated system has a compact and smooth design, integrated pneumatic lines, IP65/67 protection class and superior chemical resistance.

An explosion-proof version is also available.

Technical data	
Orifice	DN15 to DN65
Port connections	Threaded Weld and Clamp
Body material	Casted stainless steel 316L
Nominal pressure	PN25 (Body)
Actuator material	Actuator Cover
	PPS Stainless steel 1.4561 (316Ti)
Sealing material	PTFE
Medium	Water, alcohol, oils, fuels, hydraulic fluids, salt solution, alkali solutions, organic solvents, steam, optional fuel gas (EC Gas Appliances Directive 2009/142/EG)
Viscosity	max. 600 mm ² /s
Spindle packing	PTFE V-rings with spring compensation
Medium temperature	-10 to +185 °C
Ambient temperature	0 to +55 °C (integrated control head) 0 to +60 °C (push-in air ports) 0 to +100 °C (threaded air ports)
Control medium	Neutral gases, air
Max. pilot pressure	max. 10 bar; actuator size 130 mm, 7 bar
Pilot air ports	Push-in connector for external ø 6 mm or 1/4" tube, thread G1/8 (on request)
Installation	As required, preferably with actuator in upright position

Content

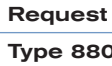
 Valve specifications Type 2100	 System spec. On/Off ELEMENT Type 8801-YE	 Request for quotation Type 8801-YE
Technical data & ordering info. p. 1-7	Technical data & ordering info. p. 8-12	p.13

Technical data angle seat valve Type 2100 flow direction below the seat (for gases and liquids)

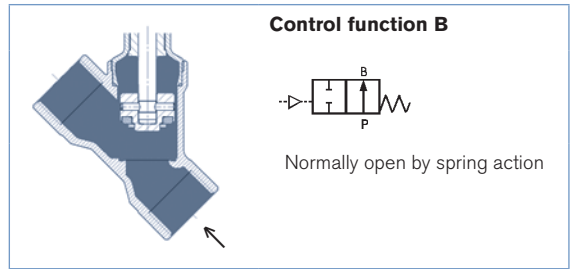
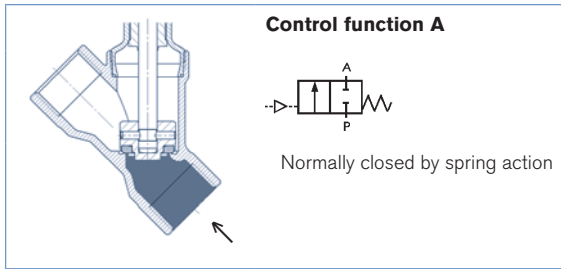

Orifice [mm]	Actuator size [mm]	Kv value water (m³/h)	Minimum pilot pressure CFA [bar]	Operating pressure up to +185°C CFA [bar]	CFB [bar]
15	50	5	5.2	25	16
	70	5	5.0	25	16
20	50	10	5.2	16	16
	70	11	5.0	20	16
25	50	15	5.2	9	14.5
	70	18	5.0	16	16
32	70	27	5.0	8.5	16
	90	28	5.0	16	16
40	70	38	5.0	6	16
	90	40	5.0	16	16
50	70	52	-	-	16
	90	55	5.0	10	16
	130	62	5.0	16	16
65	90	85	5.0	5	14
	130	95	5.6	16 (15*)	16 (15*)

* acc. to the Pressure Equipment Directive 97/23 / EC for compressible fluids in Group 1 (hazardous gases and vapors in accordance with Article 3, Section 1.3, letter a, first dash)

Flow rate: Kv value water [m³/h]: Measured at +20°C, 1 bar pressure at valve inlet and free outlet.

Pressure valves [bar]: Overpressure to the atmospheric pressure

Pressure charts with control function B and flow direction below the seat

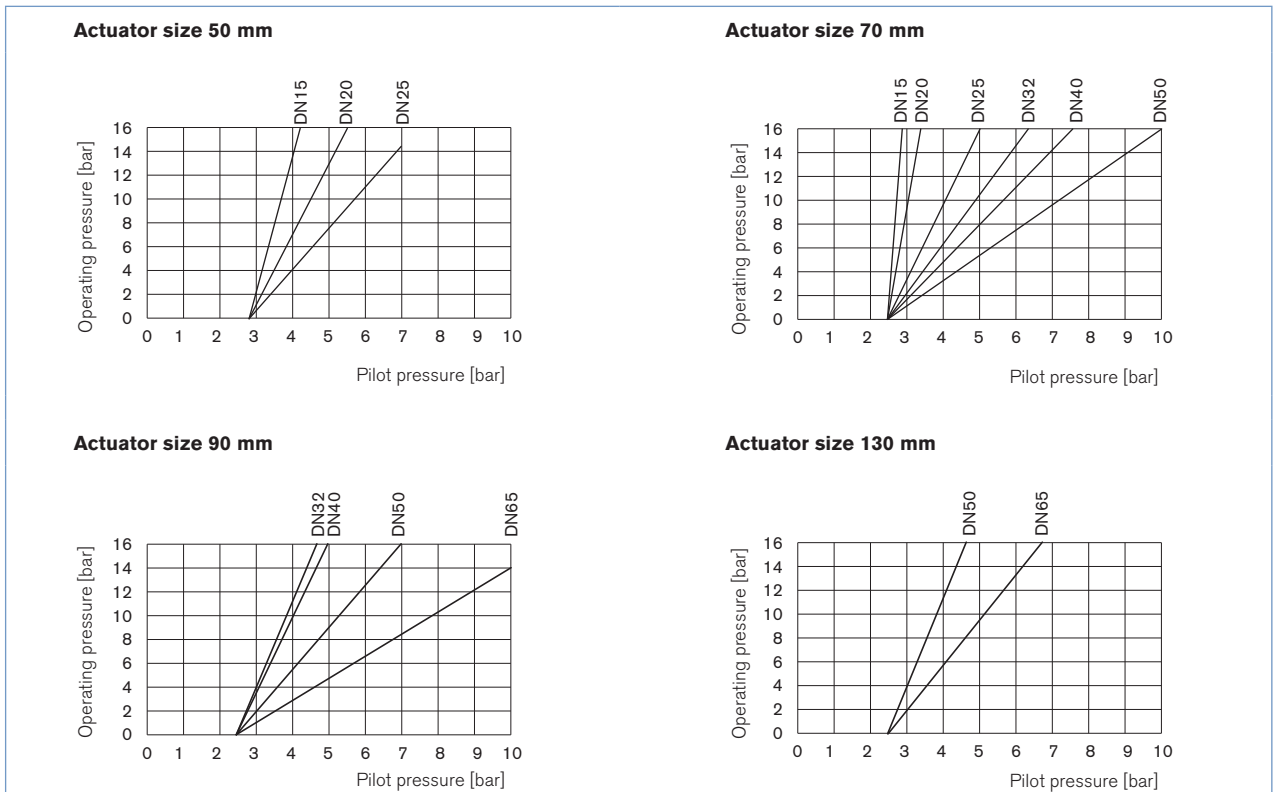

Ordering chart Type 2100, flow direction below the seat (for gases and liquids)

G threaded port, flow direction below the seat

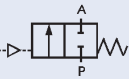
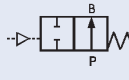
Control function	Orifice (mm)	Actuator size ϕ [mm]	Threaded port connection	Minimum pilot pressure [bar]	Operating pressure up to +185°C [bar]	Item no.	Item no. certified Atex II 2GD Mechanical
A 2/2-way valve, NC 	15	50	G 1/2"	5.2	25	213 619	259 510
		70	G 1/2"	5.0	25	213 620	259 511
	20	50	G 3/4"	5.2	16	227 616	259 513
		70	G 3/4"	5.0	20	213 621	259 515
	25	50	G 1"	5.2	9	227 617	259 516
		70	G 1"	5.0	16	213 622	259 517
	32	70	G 1 1/4"	5.0	8.5	213 623	259 519
		90	G 1 1/4"	5.0	16	213 624	259 521
	40	70	G 1 1/2"	5.0	6	213 625	259 523
		90	G 1 1/2"	5.0	16	213 627	259 524
	50	90	G 2"	5.0	10	175 108	259 525
		130	G 2"	5.0	16	188 610	259 526
	65	90	G 2 1/2"	5.0	5	239 456	259 527
		130	G 2 1/2"	5.6	16 (15*)	239 472	259 530
B 2/2-way valve, NO 	15	50	G 1/2"	see chart on p. 2	16	213 637	259 531
		70	G 1/2"		16	213 638	259 532
	20	50	G 3/4"		16	213 639	259 533
		70	G 3/4"		16	213 640	259 535
	25	70	G 1"		16	213 641	259 537
	32	70	G 1 1/4"		16	213 642	259 538
	40	70	G 1 1/2"		16	213 643	259 539
	50	70	G 2"		16	175 123	259 540
	65	90	G 2 1/2"		14	239 464	259 565
		130	G 2 1/2"		16 (15*)	239 479	259 566

NPT threaded port, flow direction below the seat

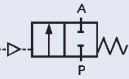
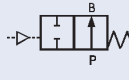
Control function	Orifice (mm)	Actuator size ϕ [mm]	Threaded port connection	Minimum pilot pressure [bar]	Operating pressure up to +185°C [bar]	Item no.
A 2/2-way valve, NC 	15	50	NPT 1/2"	5.2	25	213 644
		70	NPT 1/2"	5.0	25	213 645
	20	50	NPT 3/4"	5.2	16	227 618
		70	NPT 3/4"	5.0	20	213 646
	25	50	NPT 1"	5.2	9	227 619
		70	NPT 1"	5.0	16	213 647
	32	70	NPT 1 1/4"	5.0	8.5	213 648
		90	NPT 1 1/4"	5.0	16	213 649
	40	70	NPT 1 1/2"	5.0	6	213 650
		90	NPT 1 1/2"	5.0	16	213 651
	50	90	NPT 2"	5.0	10	188 641
		130	NPT 2"	5.0	16	188 642
	65	90	NPT 2 1/2"	5.0	5	239 457
		130	NPT 2 1/2"	5.6	16 (15*)	239 473
B 2/2-way valve, NO 	15	50	NPT 1/2"	see chart on p. 2	16	213 661
		70	NPT 1/2"		16	213 662
	20	50	NPT 3/4"		16	213 663
		70	NPT 3/4"		16	213 664
	25	70	NPT 1"		16	213 665
	32	70	NPT 1 1/4"		16	213 666
	40	70	NPT 1 1/2"		16	213 667
	50	70	NPT 2"		16	188 656
	65	90	NPT 2 1/2"		14	239 465
		130	NPT 2 1/2"		16 (15*)	239 480

* acc. to the Pressure Equipment Directive 97/23 / EC for compressible fluids in Group 1 (hazardous gases and vapors in accordance with Article 3, Section 1.3, letter a, first dash)

Ordering chart Type 2100, flow direction below the seat (for gases and liquids), *continued*

RC threaded port, flow direction below the seat

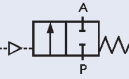
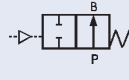
Control function	Orifice (mm)	Actuator size \varnothing [mm]	Threaded port connection	Minimum pilot pressure [bar]	Operating pressure up to +185°C [bar]	Item no.
A 2/2-way valve, NC 	15	50	RC 1/2"	5.2	25	213 668
		70	RC 1/2"	5.0	25	213 669
	20	50	RC 3/4"	5.2	16	227 621
		70	RC 3/4"	5.0	20	213 670
	25	50	RC 1"	5.2	9	227 622
		70	RC 1"	5.0	16	213 671
	32	70	RC 1 1/4"	5.0	8.5	213 672
		90	RC 1 1/4"	5.0	16	213 673
	40	70	RC 1 1/2"	5.0	6	213 674
		90	RC 1 1/2"	5.0	16	213 675
	50	90	RC 2"	5.0	10	188 664
		130	RC 2"	5.0	16	188 665
	65	90	RC 2 1/2"	5.0	5	239 458
		130	RC 2 1/2"	5.6	16 (15*)	239 474
B 2/2-way valve, NO 	15	50	RC 1/2"	see chart on p. 2	16	213 685
		70	RC 1/2"		16	213 686
	20	50	RC 3/4"		16	213 687
		70	RC 3/4"		16	213 688
	25	70	RC 1"		16	213 689
		32	70		RC 1 1/4"	16
	40	70	RC 1 1/2"		16	213 691
		50	70		RC 2"	16
	65	90	RC 2 1/2"		14	239 466
		130	RC 2 1/2"		16 (15*)	239 481

* acc. to the Pressure Equipment Directive 97/23 / EC for compressible fluids in Group 1 (hazardous gases and vapors in accordance with Article 3, Section 1.3, letter a, first dash)

i Further versions on request



Control function
I (double-acting)

Technical data angle seat valve Type 2100 flow direction above the seat (for gases and steam)

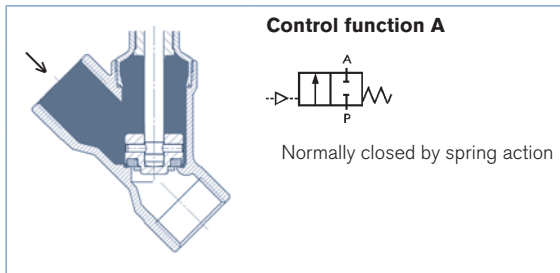

Attention!

Valves with flow above the seat are only conditionally usable for liquid medium. There is a danger of waterhammer!

Orifice [mm]	Actuator size [mm]	Kv value water (m³/h)	Operating pressure up to +185°C CFA [bar]
15	50	5	16
	70	5.1	16
20	50	10	16
	70	12	16
25	50	15	16
	70	19	16
32	70	28	16
40	70	38	16
	90	40	16
50	70	50	12
	90	55	16

Flow rate: Kv value water [m³/h]: Measured at +20°C, 1 bar pressure at valve inlet and free outlet.

Pressure valves [bar]: Overpressure to the atmospheric pressure

Pressure charts with control function A and flow direction above the seat

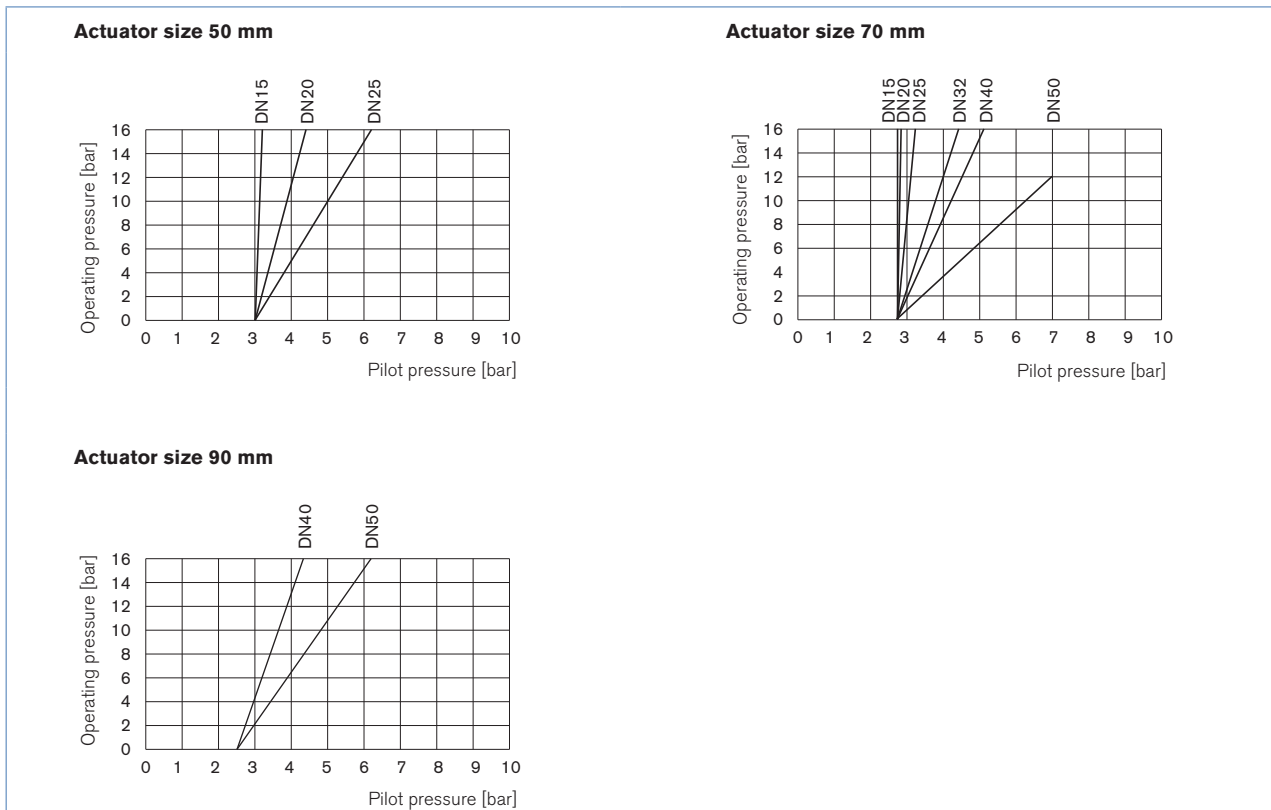

Ordering chart Type 2100 flow direction above the seat (for gases and steam)

G threaded port, flow direction above the seat

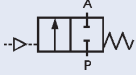
Control function	Orifice (mm)	Actuator size \varnothing [mm]	Threaded port connection	Minimum pilot pressure [bar]	Operating pressure up to +185°C [bar]	Item no.	Item no. certified Atex II 2GD Mechanical
A 2/2-way valve. NC 	15	50	G 1/2"	see chart on p. 5	16	213 628	259 567
		70	G 1/2"		16	213 629	259 568
	20	50	G 3/4"		16	213 630	259 569
		70	G 3/4"		16	213 631	259 571
	25	50	G 1"		16	213 632	259 573
		70	G 1"		16	213 633	259 575
	32	70	G 1 1/4"		16	213 634	259 576
		40	70		G 1 1/2"	16	213 635
	50		90		G 1 1/2"	16	213 636
		70	G 2"		12	175 115	259 579
	90	G 2"	16		175 116	259 580	

NPT threaded port, flow direction above the seat

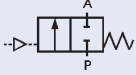
Control function	Orifice (mm)	Actuator size \varnothing [mm]	Threaded port connection	Minimum pilot pressure [bar]	Operating pressure up to +185°C [bar]	Item no.
A 2/2-way valve. NC 	15	50	NPT 1/2"	see chart on p. 5	16	213 652
		70	NPT 1/2"		16	213 653
	20	50	NPT 3/4"		16	213 654
		70	NPT 3/4"		16	213 655
	25	50	NPT 1"		16	213 656
		70	NPT 1"		16	213 657
	32	70	NPT 1 1/4"		16	213 658
	40	70	NPT 1 1/2"		16	213 659
	50	70	NPT 2"		12	188 649

RC threaded port, flow direction above the seat

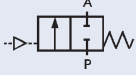
Control function	Orifice (mm)	Actuator size \varnothing [mm]	Threaded port connection	Minimum pilot pressure [bar]	Operating pressure up to +185°C [bar]	Item no.
A 2/2-way valve. NC 	15	50	RC 1/2"	see chart on p. 5	16	213 676
		70	RC 1/2"		16	213 677
	20	50	RC 3/4"		16	213 678
		70	RC 3/4"		16	213 679
	25	50	RC 1"		16	213 680
		70	RC 1"		16	213 681
	32	70	RC 1 1/4"		16	213 682
	40	70	RC 1 1/2"		16	213 683
	50	70	RC 2"		12	188 672

Materials angle seat valve Type 2100

A	Ground terminal	Stainless steel 1.4301/1.4305 <i>Only for the ATEX version</i>
1	Optical position indicator	Transparent cap polysulfone PSU
2	Pilot air ports	Push-in connector PP (standard) <i>On request:</i> Thread G1/8" stainless steel 1.4305
3	Actuator	PPS
4	Cover	Stainless steel 1.4561 (316Ti)
5	Piston seal	FKM
6	Spring	Stainless steel 1.4310
7	Pipe	Stainless steel 1.4401 (316)/1.4404 (316L)
8	Spindle packing	PTFE
9	Spindle	Stainless steel 1.4401 (316)/1.4404 (316L)
10	Spindle guide	PEEK
11	Swivel plate	Stainless steel 1.4401 (316)/1.4404 (316L)
12	Seals	PTFE
13	Valve body	Stainless steel 316L

Lubricants for spindle packing and actuator are classified according NSF H1

Dimensions angle seat valve Type 2100 [mm]

Push-in connector for plastic tube - \varnothing 6/4 mm or thread G 1/8"

Orifice [mm]	Actuator size [mm]	\varnothing A	F	G	R	HM	BM	CM	LM	SW	G D	E	NPT D	E	Rc D	E
15	50	64.5	19.8	6.1	17.15	158	185	24	65	27	G 1/2	14	NPT 1/2	13.7	RC 1/2	13.2
	70	91	23.3	8.5	30.5	173	201									
20	50	64.5	19.8	6.1	17.15	166	195	27	75	34	G 3/4	16	NPT 3/4	14	RC 3/4	14.5
	70	91	23.3	8.5	30.5	181	211									
25	50	64.5	19.8	6.1	17.15	172	204	29.5	90	41	G 1	18	NPT 1	16.8	RC 1	16.8
	70	91	23.3	8.5	30.5	195	235									
32	70	91	23.3	8.5	30.5	195	235	36	110	50	G 1 1/4	16	NPT 1 1/4	17.3	RC 1 1/4	19.1
	90	120	23.3	8.5	30.5	240	277									
	70	91	23.3	8.5	30.5	197	236									
40	90	120	23.3	8.5	30.5	242	278	35	120	55	G 1 1/2	18	NPT 1 1/2	17.3	RC 1 1/2	19.1
	130	159	23.3	8.5	30.5	293	328									
	70	91	23.3	8.5	30.5	214	262									
50	90	120	23.3	8.5	30.5	255	301	45	150	70	G 2	24	NPT 2	17.6	RC 2	23.4
	130	159	23.3	8.5	30.5	306	351									
	90	120	23.3	8.5	30.5	270	328									
65	90	120	23.3	8.5	30.5	270	328	57	185	85	G 2 1/2	26	NPT 2 1/2	23.7	RC 2 1/2	26.7
	130	159	23.3	8.5	30.5	321	378									

**2100 threaded
System On/Off
ELEMENT 8801-YE**

Ordering information for valve system On/Off ELEMENT Type 8801-YE

A **valve system On/Off ELEMENT Type 8801-YE** consists of a **angle seat valve Type 2100** and a valve actuation system control head **Type 8691/8695** or a pneumatic control unit **Type 8690/8697** (see separate datasheets).

For the configuration of further valve systems please use the "Request for quotation" on p. 14-15.

[go to page](#)

You order two components and receive a complete assembled and certified valve.

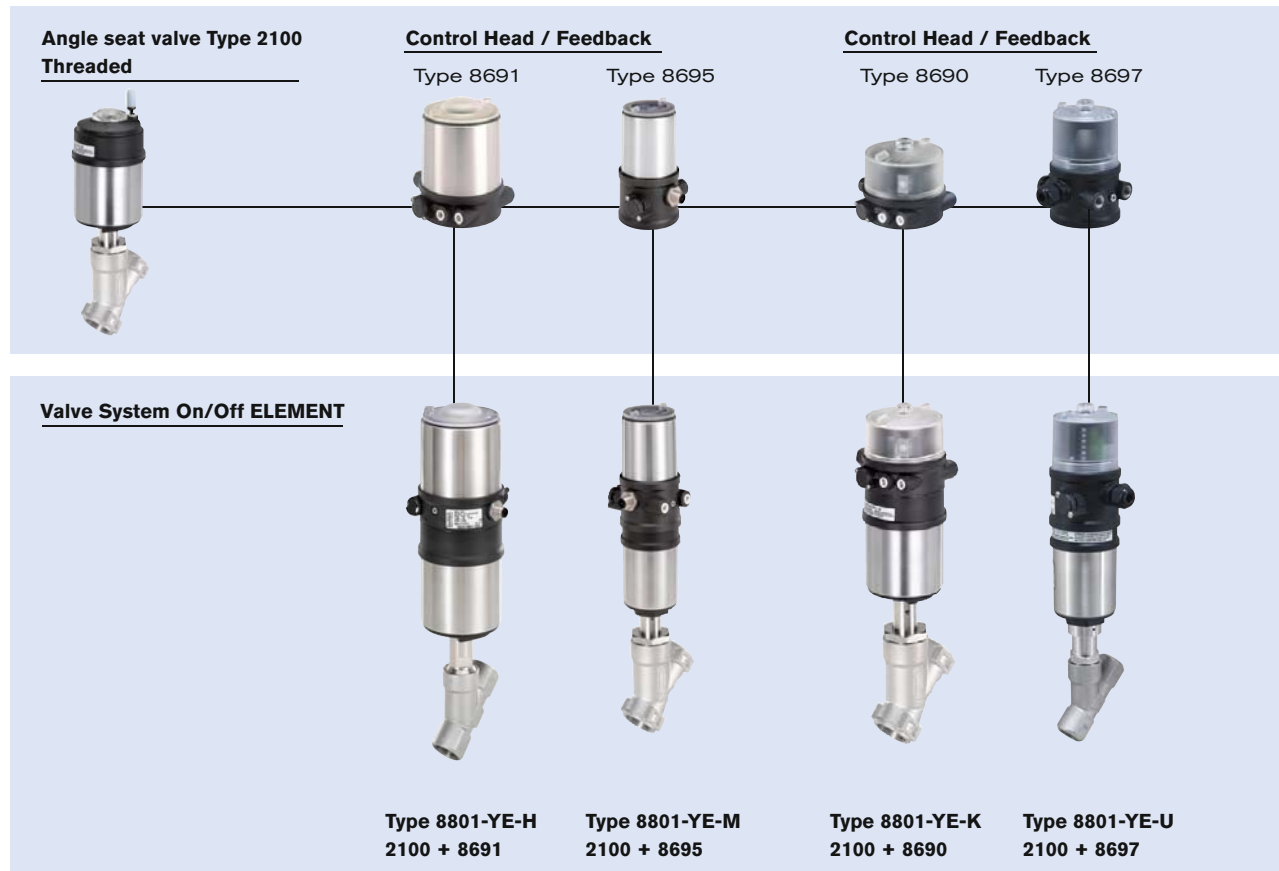

A detailed description of the control heads and pneumatic control units is on the next page. →

Ordering information for valve system On/Off ELEMENT Type 8801-YE, *continued*

Control Head / Feedback



More info.



More info.

Type 8691

Actuator size 70/90/130

Type 8695

Actuator size 50

The Control Head Type 8691/ 8695 is optimised for integrated mounting on the 21XX process valve series. The registration of the valve end position is done through a contactless analog position sensor, which automatically recognises and saves the valve end position through the Teach function when starting up. The integrated pilot valve controls single or double-acting actuators. The status of the valve is shown through high power coloured LEDs.

Features

- High power coloured Status-LEDs
- Contactless inductive position sensor
- Pilot valve with manual override
- Teach function for automatic registration of valve positions
- Hygienic stainless steel design
- Easy to clean chemically resistant housing featuring IP65 / IP67, 4X Rating
- AS-Interface or DeviceNet Fieldbus communication

Benefits

- Easy and safe Start-up through Teach function
- Easy process monitoring and error detection through clearly visible high-power coloured LEDs
- High plant availability due to prolonged actuator life boosted by spring chamber ventilation
- Minimised space requirement in the plant piping for more flexibility in plant design

Pneumatic Control Unit / Feedback



More info.



More info.

Type 8690

Actuator size 70/90/130

Type 8697

Actuator size 50

The pneumatic control unit Type 8697/8690 is optimised for integrated mounting on the 21XX process valve series. Mechanical or inductive limit switches register the position of the valve. The integrated pilot valve controls single or double-acting (8690) actuators.

Features

- Visual position indicator
- Mechanical or inductive limit switches for end position registering
- Pilot valve with manual override
- Compact design
- Easy to clean chemically resistant housing featuring IP65 / IP67, 4X Rating
- Optional intrinsically safe version acc. to ATEX

Benefits

- Easy and safe Start-up through Teach function (Type 8697)
- High level of signal reliability thanks to self adjusting limit switches
- Minimised space requirement in the plant piping for more flexibility in plant design

Click on the orange box "More info"... you will come to our website for the resp. product where you can download the data sheet.

Dimensions for valve system On/Off ELEMENT Type 8801-YE [mm]

Dimensions valve system On/Off ELEMENT Type 8801-YE-K (with pneumatic control unit Type 8690)

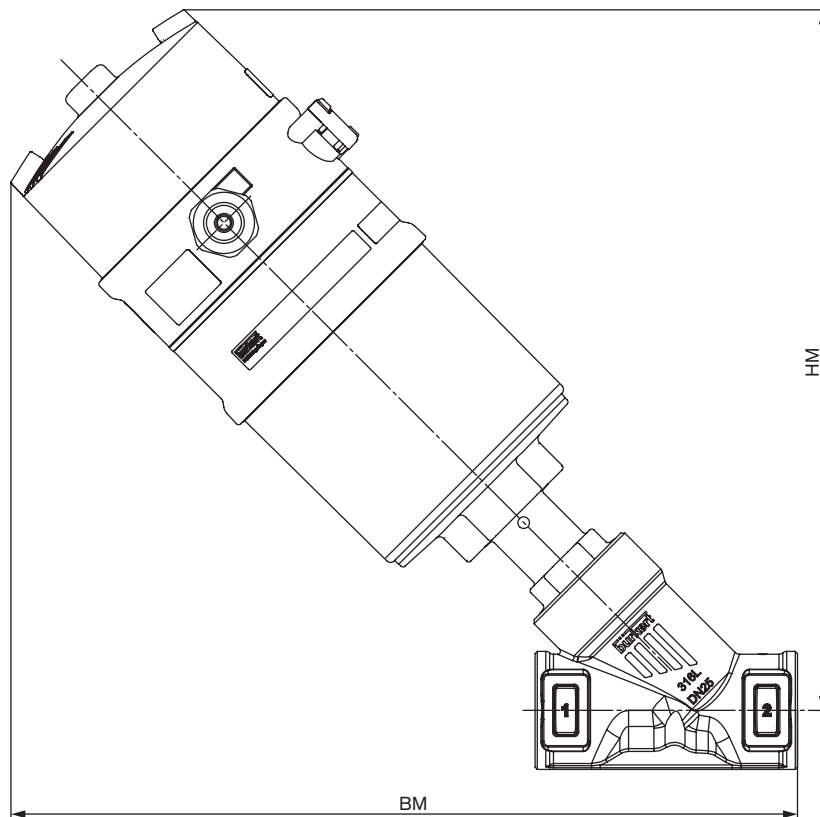

Orifice [mm]	Actuator size [mm]	HM	BM
15	70	227	255
20	70	235	265
25	70	241	274
32	70	249	289
	90	292	329
40	70	251	290
	90	294	330
	130	331	366
50	70	268	316
	90	307	353
	130	344	389
65	90	322	380
	130	359	416

Further dimensions see p. 7

**2100 threaded
System On/Off
ELEMENT 8801-YE**

Dimensions for valve system On/Off ELEMENT Type 8801-YE [mm]

Dimensions valve system On/Off ELEMENT Type 8801-YE-K (with pneumatic control unit Type 8697)

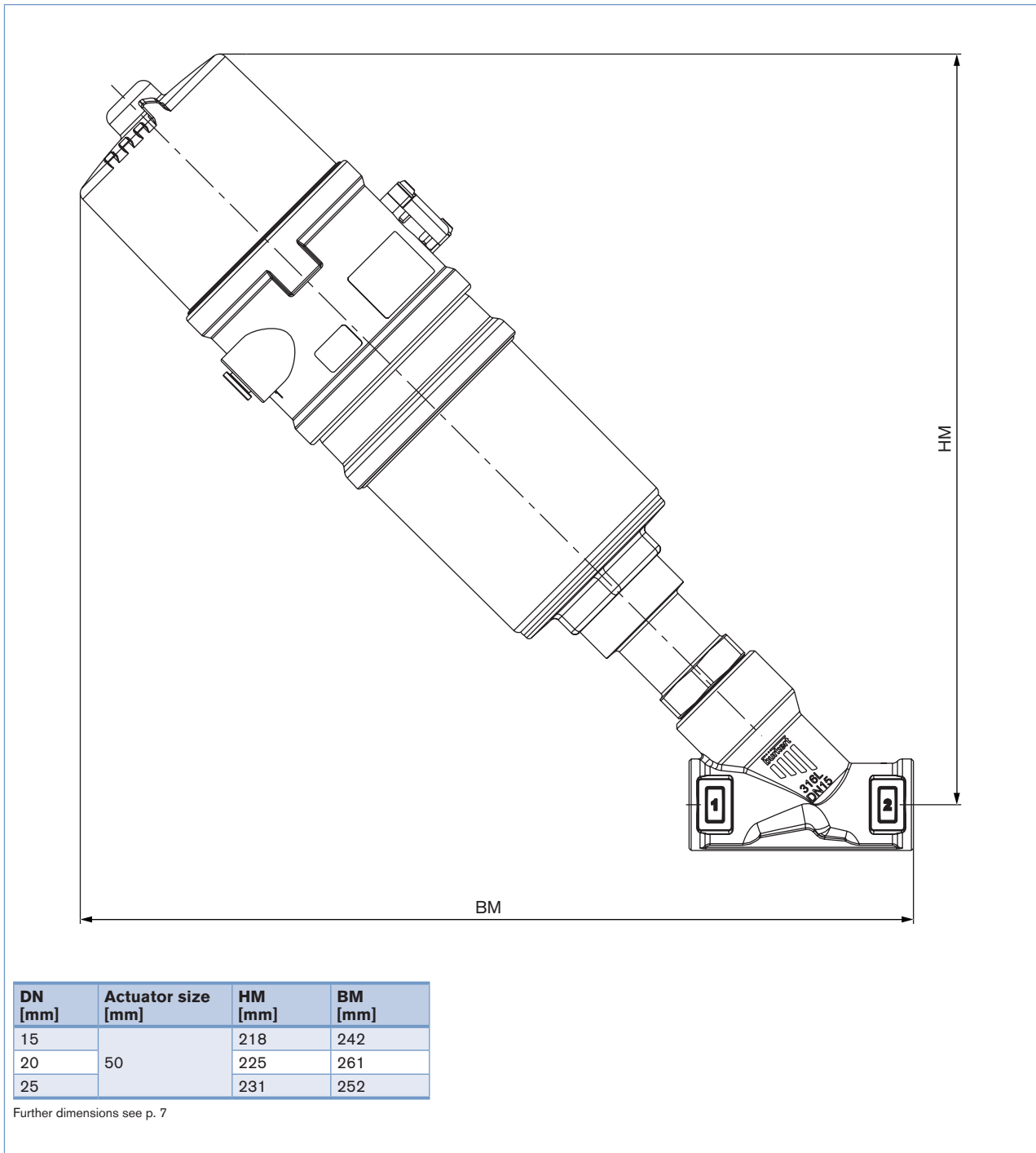

Dimensions for valve system On/Off ELEMENT Type 8801-YE [mm], *continued*

Dimensions valve system On/Off ELEMENT Type 8801-YE-H (with control head Type 8691)

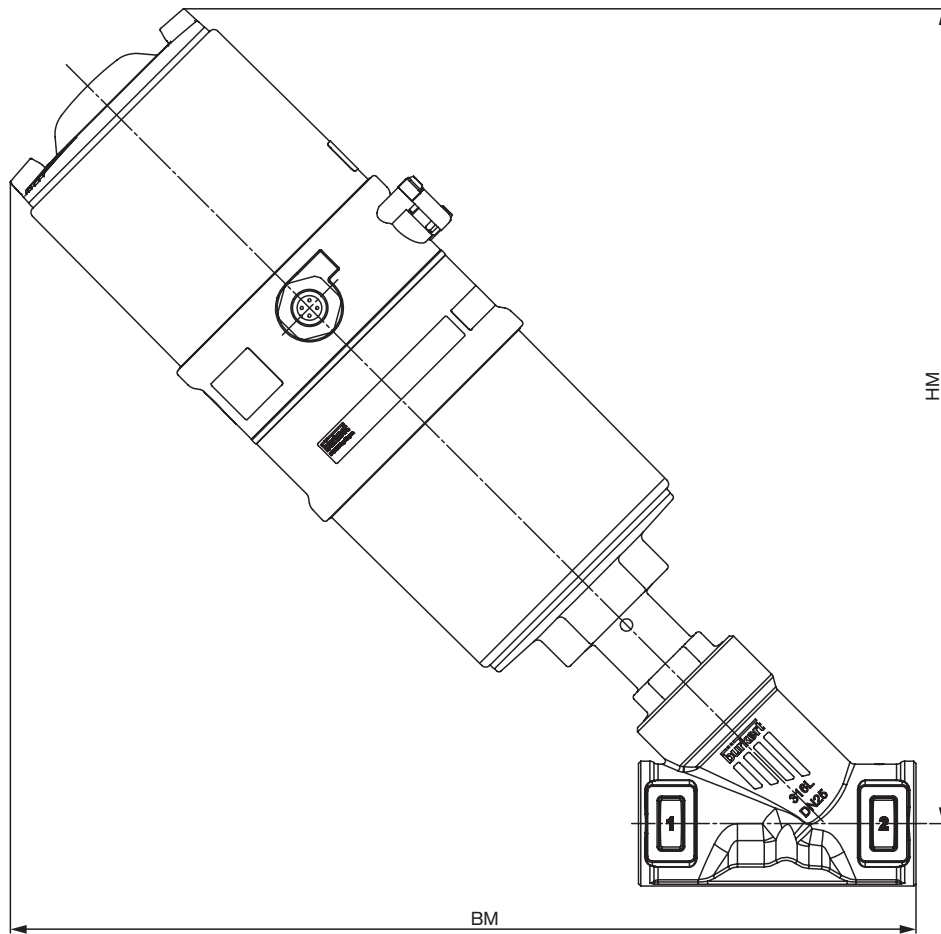

Orifice [mm]	Actuator size [mm]	HM	BM
15	70	251	279
20	70	259	289
25	70	265	298
32	70	273	313
	90	316	353
40	70	275	314
	90	318	354
	130	355	390
50	70	292	340
	90	331	377
	130	368	413
65	90	346	404
	130	383	440

Further dimensions see p. 7

Dimensions for valve system On/Off ELEMENT Type 8801-YE [mm], *continued*

Dimensions valve system On/Off ELEMENT Type 8801-YE-M (with control head Type 8695)

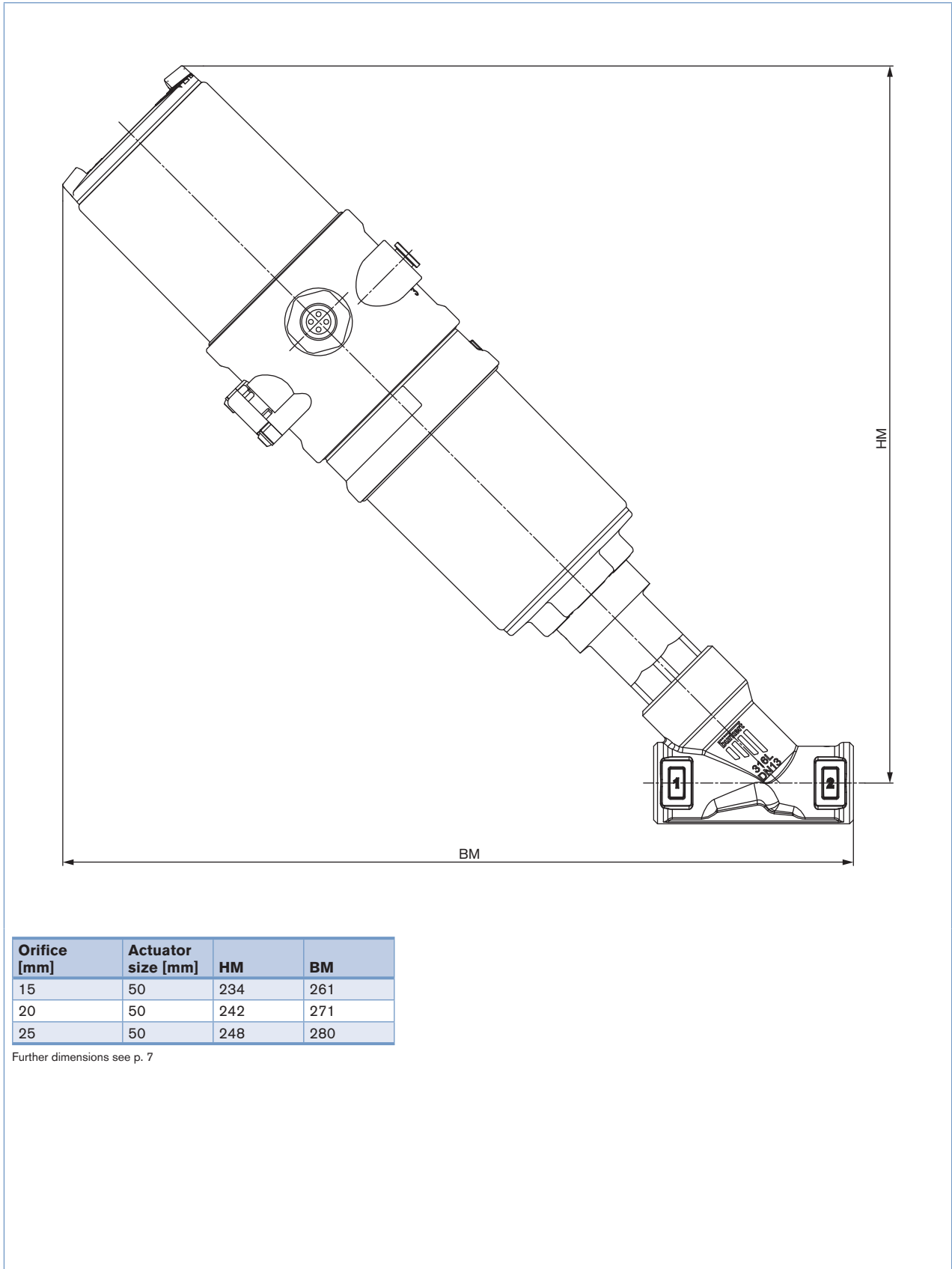

Orifice [mm]	Actuator size [mm]	HM	BM
15	50	234	261
20	50	242	271
25	50	248	280

Further dimensions see p. 7

Note
You can fill out the fields directly in the PDF file before printing out the form.

Valve system On/Off ELEMENT Type 8801-YE – request for quotation

▶ Please fill out and send to your nearest Bürkert facility* with your inquiry or order

Company	Contact person
Customer no.	Department
Address	Tel./Fax
Postcode/town	E-Mail

= mandatory fields to fill out Quantity Required delivery date

Operating data

Pipe line DN PN

Pipe material

Process medium

Type of media Liquid Steam Gas

Valve features

Seal material PTFE NBR Other

Nominal pressure PN

Orifice DN

Type of connection Threaded Welded Clamp

Standard connection ISO DIN Other

Body material selection with welded connection acc. to EN ISO 1127/ISO 4200 and DIN 11850
 Stainless steel 316L

Control function NC ¹⁾ NO ¹⁾ Double-acting

Pilot pressure min. max.

Atex II 2GD Mechanical

Please specify item no. (if known):









¹⁾NC: normally closed by spring action; NO: normally open by spring action

Continued on next page →

Valve system On/Off ELEMENT Type 8801-YE – request for quotation, *continued*

Automation unit features

Click on the orange box "More info"... you will come to our website for the resp. product where you can download the data sheet.

Control Head / Feedback		Pneumatic Control Unit / Feedback	
<input type="checkbox"/> Type 8691  For actuator size 70/90/130 	<input type="checkbox"/> Type 8695  For actuator size 50 	<input type="checkbox"/> Type 8690  For actuator size 70/90/130 	<input type="checkbox"/> Type 8697  For actuator size 50 
<ul style="list-style-type: none"> Inductive position sensor with automatic Teach function Coloured high power LEDs With/without pilot valve for single or double-acting actuators Fieldbus communication Hygienic stainless steel design 		<ul style="list-style-type: none"> visual status indicator Micro- or proximity switches for end position feedback With/ without pilot valve for single or double-acting actuators Optional intrinsically safe version acc. to ATEX / IECEx 	
Pneumatic function <input type="checkbox"/> Single-acting <input type="checkbox"/> Double-acting <input type="checkbox"/> Without pilot valve	Electrical connection <input type="checkbox"/> Cable gland <input type="checkbox"/> M12 connector	Pneumatic function <input type="checkbox"/> Single-acting <input type="checkbox"/> Double-acting (only with 8690) <input type="checkbox"/> Without pilot valve	Number of Position feedback switches <input type="checkbox"/> 1x <input type="checkbox"/> 2x
Communication <input type="checkbox"/> AS-Interface <input type="checkbox"/> DeviceNet <input type="checkbox"/> without	Approvals <input type="checkbox"/> ATEX cat. 3GD, IECEx <input type="checkbox"/> without	Position feedback switches <input type="checkbox"/> Micro-switch 24V DC <input type="checkbox"/> Micro-switch 50 – 225 V DC/AC (only 8697) <input type="checkbox"/> Inductive switch 3-wire PNP <input type="checkbox"/> Inductive switch 2-wire NAMUR <input type="checkbox"/> Inductive switch 2-wire 24V DC <input type="checkbox"/> without	Electrical connection <input type="checkbox"/> Cable gland <input type="checkbox"/> M12 connector
			Approvals <input type="checkbox"/> ATEX cat. 3GD, IECEx <input type="checkbox"/> ATEX cat. 2DG, IECEx <input type="checkbox"/> without

Certifications

- Attestation of compliance with the order EN-ISO 10204 2.1 (Item-No. 440 788)
- Test report EN-ISO 10204 2.2 (Item-No. 803 722)
- Certification of Conformity for Raw Material EN-ISO 10204 3.1 (Included in delivery)
- EN161 (European Gas Device guideline)
- FDA and USP compliance

Comment /sketch

*To find your nearest Bürkert facility, click on the orange box → www.burkert.com

In case of special application conditions, please consult for advice.

Subject to alteration.
© Christian Bürkert GmbH & Co. KG

1605/17_EU-en_00895001

DTS 1000095355 EN Version: Q Status: RL (released | freigegeben | valide) printed: 24.10.2016