



Direct acting 2/2 or 3/2 way Pivoted armature valve

- Direct acting, medium separated valve up to orifice DN 4
- Maintenance-free pivoted armature technology
- Vibration resistant, screwed block coil system
- Suitable for aggressive alkali solutions and acids
- Service friendly, robust manual override
- Explosion proofed version

The 0331 valve is a direct-acting, media-separated pivoted armature valve. It is available in 3/2 and 2/2-way versions. As a 3/2-way version, it can be used as a distributor or mixing valve. Various diaphragm material combinations and methods of operation are available depending on the application. The standard brass housing satisfies all European drinking water requirements. Stainless steel (316L), PVDF, polypropylene and PEEK housing versions complete the offering. The solenoid coils are moulded with a chemically resistant epoxy. The 0331 is equipped with manual override for commissioning and testing. For reduced energy requirements all coils can be delivered with electronic power reduction or as an impulse version. The switching status can be indicated with position feedback as a binary or NAMUR signal. In combination with a plug in accordance with DIN EN 17301-803 Form A, the valves satisfy protection class IP65/67 – in combination with a stainless steel or plastic housing NEMA 250 Kat.4X.

Contents:

Standard version

Technical data	p. 1
Additional options	p. 4
Dimensions & Pin Assignment	p. 5
Ordering chart	p. 6

Explosion proofed version

Technical data	p. 8
Additional options	p. 10
Dimensions & Pin Assignment	p. 11
Ordering chart	p. 12

Technical data	
Available body material	Brass Stainless steel (1.4401) PP (Polypropylene) PVDF (Polyvinyl fluoride) PEEK
Port connection	Flange interface acc. to Bürkert standard 1000225877 (see also sectional dimensions)
Medium	
for NBR	Neutral mediums such as compressed air, town gas, water, hydraulic oil, oils and greases without additives, oxygen
for EPDM	Alkalis, acids to medium concentrations, alkaline washing and bleaching lyes
for FKM	Oxidizing acids and substances, hot oils with additives, salt solutions, waste gases, oxygen
for FFKM	Aggressive mediums, hot air, hot oils
All materials	For more detailed information please refer to our compatibility chart
Medium temperature for body material Brass, Stainless Steel or PEEK	NBR 0 to +80°C EPDM -30 to +90°C FKM 0 to +90°C FFKM +5 to +90°C
Medium temperature for body material PP or PVDF	NBR 0 to +80°C EPDM -30 to +80°C FKM 0 to +80°C FFKM +5 to +80°C
Viscosity	Max. 37mm ² /s
Ambient temperature	Max. +55°C
Operating voltage	24V 50Hz; 110V 50Hz; 230V 50Hz 120V 60Hz; 240V 60Hz 12V DC; 24V DC; (further voltages on request)
Voltage tolerance	+/- 10%
Duty cycle for brass and stainless steel	100%
Duty cycle for PP PVDF PEEK	40% ED (60% intermittent operation) in 30min for 8W version 100% ED for 5W version 60% ED (40% intermittent operation) in 30min for 8W version

Circuit function

- A** 2/2-way direct acting valve, normally closed

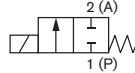

- B** 2/2-way direct acting valve, normally open

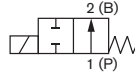

- C** 3/2-way valve, direct acting, when de-energised Port A exhausted

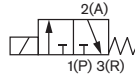

- D** 3/2-way valve, servo-assisted, outlet B normally pressurized

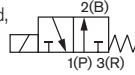

- E** Mixer valve, direct-acting, in de-energized position, P2→A open, P1 closed

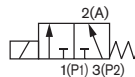

- F** Distribution valve, direct-acting, in de-energized position, P→B open, A closed

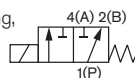

- T** 3/2 way valve, universal function, flow direction as required

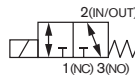

Technical data (continued)

Electrical connection	Tag connector acc. to DIN EN 175301-803 Form A for cable plug Type 2508/2509 (on request also with moulded cable or terminal box)
Type of protection	IP65 with cable plug
Coil thermal isolation class	H
Installation	As required, preferably with actuator upright
Weight [kg]	
with metal body	0.47
with plastic body	0.40

Standard power consumption

FrequencyAC			FrequencyDC	
Inrush [VA]	Hold [VA]	Operation [W]	Cold [W]	Warm [W]
30	15	8	11	8

Impulse (inrush winding)

FrequencyAC		FrequencyDC	
Hold [VA]	Operation [W]	Cold [W]	Warm [W]
20	11	11	8

Response times

Orifice [mm]	FrequencyAC		FrequencyDC	
	Opening [ms]	Closing [ms]	Opening [ms]	Closing [ms]
2-4	8-15	8-15	10-20	10-20

Response times [ms]:

Measured at valve outlet at 6 bar and +20 °C

Opening: Pressure rise 0 to 90%,

Closing: Pressure relief 100 to 10%

Pressure range and flow rate for brass, stainless steel or PEEK body

Circuit function	DN	Kv value [m ³ /h]:		Standard ¹⁾		Impulse ²⁾
		DC	AC [50 or 60hz]	Pressure range ⁴⁾ [bar]	Vaccum ³⁾ Pressure range ⁴⁾ [bar]	Pressure range ⁴⁾ [bar]
A / B / C / D / F	2.0	0.08	0.10	0 - 16 ⁵⁾	-0.98 - 10	0 - 16 ⁵⁾
	3.0	0.12	0.15	0 - 10	-0.98 - 6	0 - 10
	4.0	0.15	0.18	0 - 5	-0.98 - 3	0 - 5
E	2.0	0.08	0.10	0 - 10	-0.98 - 8	0 - 10
	3.0	0.12	0.15	0 - 6	-0.98 - 5	0 - 6
	4.0	0.15	0.18	0 - 3	-0.98 - 2.5	0 - 3
T	2.0	0.08	0.10	0 - 12	-0.98 - 8	-
	3.0	0.12	0.15	0 - 8	-0.98 - 5	-
	4.0	0.15	0.18	0 - 4	-0.98 - 3	-

Pressure range and flow rate PVDF or PP body

Circuit function	DN	Kv value water		Standard ¹⁾		Vacuum Pressure range ⁴⁾ [bar]	Impulse ²⁾ Pressure range ⁴⁾ [bar]
		[m ³ /h]		Pressure range ⁴⁾ [bar] AC [50 or 60hz]	Pressure range ⁴⁾ [bar] DC		
A / B / C / D / F	2.0	0.1		0 - 16 ⁵⁾	0 - 12	-0.98 - 10	0 - 12
	3.0	0.15		0 - 10	0 - 8	-0.98 - 6	0 - 8
	4.0	0.18		0 - 5	0 - 4	-0.98 - 3	0 - 4
E / T	2.0	0.1		0 - 10	0 - 7	-0.98 - 7	0 - 7
	3.0	0.15		0 - 6	0 - 4	-0.98 - 5	0 - 4
	4.0	0.18		0 - 3	0 - 2.5	-0.98 - 2.5	0 - 2

¹⁾ Heat output 8 W

²⁾ Inrush power 11 W

³⁾ Vacuum possible for all seal materials

⁴⁾ Pressure values [bar] for atmospheric pressure

⁵⁾ For seal material FKM and FFKM the max. medium pressure is 12 bar

Use in other circuit functions

The valves are fitted with different springs for a particular circuit function

When used in other circuit functions, the maximum operating pressure varies according to the following tables

Metal body (8W respectively 11W)																		
Circuit function	Max. operating pressure [bar] when using the valve in a new circuit function																	
	Orifice 2 mm						Orifice 3 mm						Orifice 4 mm					
	A ¹⁾	B ¹⁾	C	D	E	F	A	B	C	D	E	F	A	B	C	D	E	F
C	16	1.5	16	1.5	1.5	16	10	1	10	1	1	10	5	0.8	5	0.8	0.8	5
D	4	16	4.5	16	4	4	2.5	10	2.5	10	2	3	2	5	2	5	2	2
T	8	8	10	10	10	8	6	6	6	6	6	6	3	3	3	3	3	3

Plastic body (8W respectively 11W)																		
Circuit function	Max. operating pressure [bar] when using the valve in a new circuit function																	
	Orifice 2 mm						Orifice 3 mm						Orifice 4 mm					
	A ¹⁾	B ¹⁾	C	D	E	F	A	B	C	D	E	F	A	B	C	D	E	F
C	16	1.5	16	1.5	1.5	16	10	1	10	1	1	10	5	0.8	5	0.8	0.8	5
D	4	16	4.5	16	4	4	2.5	10	2.5	10	2	3	2	5	2	5	2	2
F	16	1.5	10	1.5	1.5	16	6	1	6	1	1	10	4	1	4	1	1	

¹⁾ For circuit function A and B the valve must be connected acc. to the pin assignment of 3/2-way valve.

Construction and material specifications

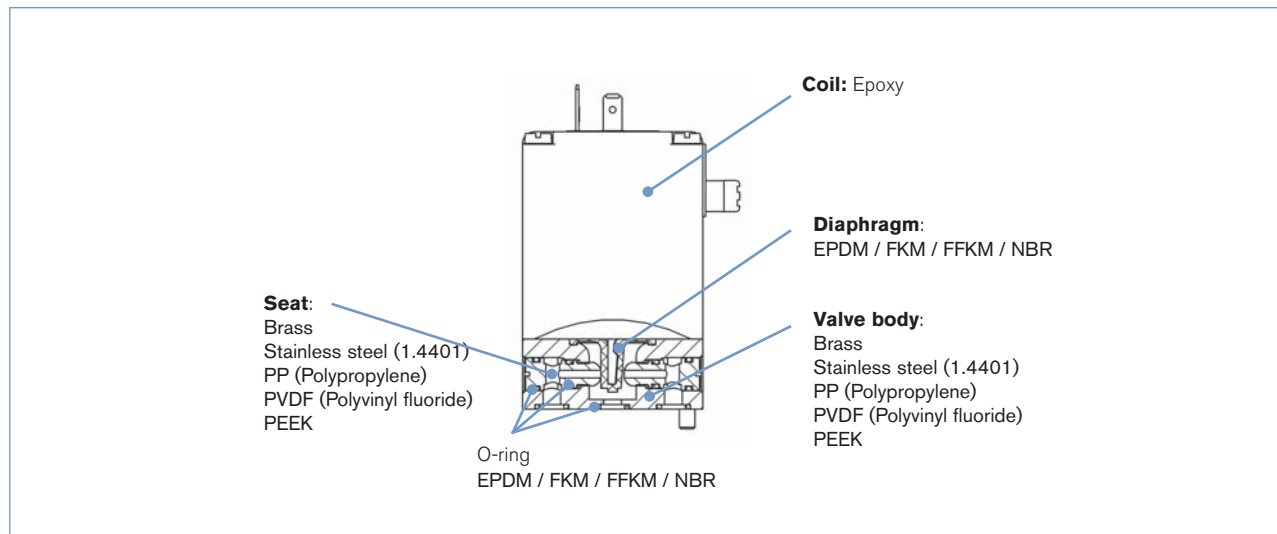

Additional options

Option	Var. Code	Description
Impulse version	CF02	Bistable magnetic system with inrush and drop-off coil; Continuous operation or operation with short current pulses (min. 150 ms) possible
Oxygen versions	NL02	Suitable for applications with oxygen (non-metal materials that are in contact with the medium, are tested and approved according to BAM)
Increased purity requirements e.g. oil, grease and silicone-free	NL50/NL05	Wetted parts are specially cleaned and packaged in accordance with the valves
Increased tightness requirements	PCxx	Standard units are tested at 10^{-2} mbar x l / sec; feasible up to 10^6 mbar
Electrical feedback	LF02 / LF03	See Type 1060
High-power electronics	CZ05	Inrush power 60 W, nominal holding current 3 W; with plastic versions 100% ED is now feasible
Vacuum version	NA02	Suitable for vacuums up to -0.98bar
Increased purity and tightness requirements	NA03	Wetted parts are specially cleaned and leak tested to 10^{-4} mbar x l/sec
Increased purity and tightness requirements and vacuum version	NA01	Wetted parts are specially cleaned and leak tested up to 10^{-4} mbar x l/sec and suited for vacuum up to -0.98 bar
Coil with reduced power (5W)		Devices have lower pressure range; with plastic versions 100% ED is now feasible
Cable plug	JFxx / JGxx	Cable plug is included in delivery. Cable plug versions (acc. to DIN EN 175301-803 Form A), see datasheet Type 2508 and 2509
Manifold with banjo bolt	LG09	Due to the banjo bolt a direct attachment is possible (for example, to externally controlled pneumatic drives)
Approvals	PD01	CSA General Purpose valve
	PD02	UL recognized General Purpose valve CSA General Purpose valve
	PD45	FM explosionproof for class I Div. 1 and dust-ignitionproof for class II / III Div. 1 T4 CSA General Purpose valve for hazardous location class I / II Div.2 and class III T4
	PD07	DNV-GL (formerly Germanischer Lloyd)
possible conformities (depending on the assembly)		EAC ; drinking water; FDA;

Dimensions [mm]

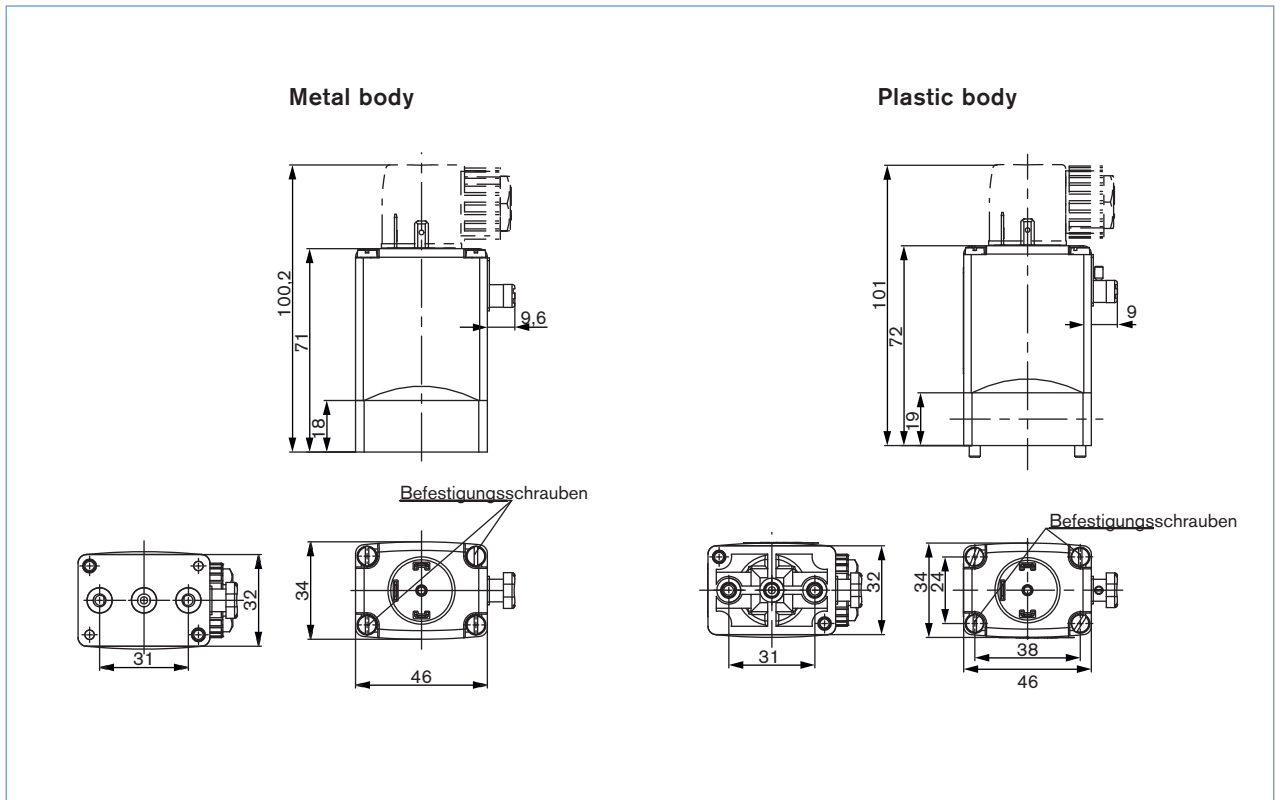

PIN Assignments

The connections marked with 1, 2 and 3 are labelled in the drawing according to the circuit function table on the left.

Circuit function	Connection 1	Connection 2	Connection 3
A	P	A	
B	B	P	
C	P	A	R
D	R	B	P
E	P1	A	P2
F	A	P	B

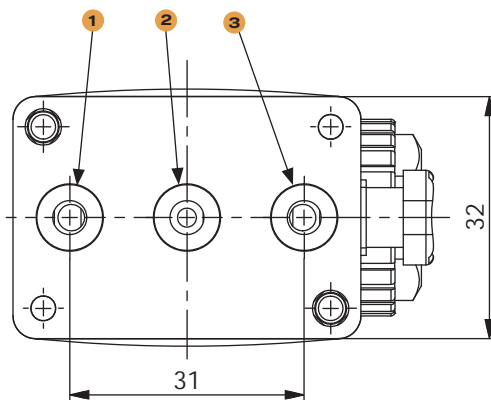

Ordering chart (products with reduced delivery time)

All devices with manual override and cable plug Type 2508

Circuit function	Orifice [mm]	Seal Material	Body and seat material	Item no. per voltage/frequency [V/Hz]			
				024/DC	024/50	110/50	230/50
A	04.0	FKM	Polypropylene	088 352	-	-	020 278
C	02.0	NBR	Brass	041 183	041 184	044 989	041 188
	02.0	FKM	Stainless steel	048 354	-	-	-
	02.0	EPDM	PVDF	-	-	-	130 301
	03.0	NBR	Brass	041 195	041 198	041 203	041 209
	03.0	FKM	Stainless steel	045 796	-	-	-
D	02.0	NBR	Brass	041 234	041 235	041 798	041 242
	02.0	EPDM	PVDF	079 663	-	-	-
	02.0	FKM	PVDF	-	-	-	078 859
	03.0	NBR	Brass	041 247	041 248	041 531	041 254
E	02.0	NBR	Brass	042 061	042 799	040 064	041 265
	03.0	NBR	Brass	042 980	043 104	046 843	041 270
	03.0	EPDM	Polypropylene	021 892	-	-	-
T	02.0	FKM	Brass	124 953	124 954	124 955	124 956
	03.0	FKM	Brass	124 958	124 959	124 960	124 961

Ordering chart (products with reduced delivery time)

All devices with manual override and cable plug Type 2508 and manifold (banjo version)

Circuit function	Orifice [mm]	Seal Material	Body and seat material	Item no. per voltage/frequency [V/Hz]			
				024/DC	024/50	110/50	230/50
C	02.0	NBR	Brass	041 191	-	-	041 192
	03.0	NBR	Brass	041 217	041 219	041 223	041 228
	03.0	FKM	Brass	041 231	-	-	041 233
E	02.0	NBR	Brass	123 092	-	-	043 913

Ordering chart for flange valve manifolds and accessories

Manifolds (the plates connecting thread is G1/4)

Number of valve positions [mm]	Length A	Hole spacing B [mm]	Item no.		
			Material, aluminum anodized	Material, stainless steel	Material, brass
1	32	–	5043	679 211	006 014
2	69	–	5045	679 209	612 071
3	106	37	5366	679 266	006 323
4	143	74	5294	658 925	006 324
5	180	111	5295	679 268	006 325
6	217	148	5296	679 269	006 326
7	254	185	5403	679 270	006 327
8	291	222	6074	679 271	–

Accessories for manifolds

	Material	Seal material	Item No.
Covering plate (for empty valve places)	Stainless steel	FKM	265 294
Covering plate (for empty valve places)	Aluminium anodized	NBR	005 625
Nipple (for connecting the collecting ducts of 2 manifolds)	Steel lined	FKM	005 049
Nipple (for connecting the collecting ducts of 2 manifolds)	Stainless steel	FKM	007 376
Nipple (for connecting the manifolds; connecting duct is closed)	Steel lined	NBR	006 049

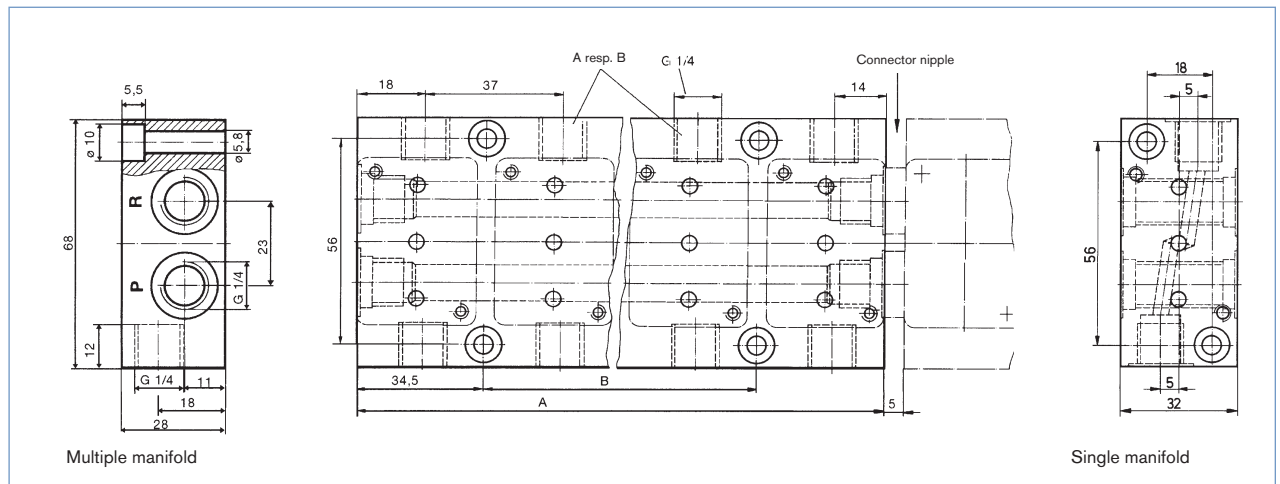



Circuit function

- A** 2/2-way direct acting valve, normally closed
- B** 2/2-way direct acting valve, normally open
- C** 3/2-way valve, direct acting, when de-energised Port A exhausted
- D** 3/2-way valve, servo-assisted, outlet B normally pressurized
- E** Mixer valve, direct-acting, in de-energized position, P2→A open, P1 closed
- F** Distribution valve, direct-acting, in de-energized position, P→B open, A closed
- T** 3/2 way valve, universal function, flow direction as required

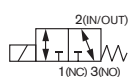
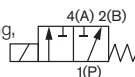
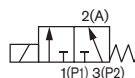
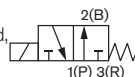
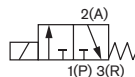
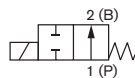
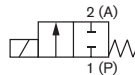

Explosion proofed version

Technical data	
Available body material	Brass, stainless steel (1.4401), PP (Polypropylene) PVDF (Polyvinyl fluoride), PEEK
Port connection	Flange interface acc. to Bürkert standard 1000225877 (see also sectional dimensions)
Seal material	EPDM / FKM / FFKM / NBR
Medium	
for NBR	Neutral mediums such as compressed air, town gas, water, hydraulic oil, oils and greases without additives, oxygen
for EPDM	Alkalis, acids to medium concentrations, alkaline washing and bleaching lyes
for FKM	Oxidizing acids and substances, hot oils with additives, salt solutions, waste gases, oxygen
for FFKM	Aggressive mediums, hot air, hot oils
All materials	For more detailed information please refer to our compatibility chart
Medium temperature for body material	NBR 0 to +80°C
Brass, Stainless steel or PEEK	EPDM -30 to +90°C
Medium temperature for body material PP or PVDF	FKM 0 to +90°C
	FFKM +5 to 90°C
Viscosity	Max. 37 mm ² /s
Ambient temperature	Max. +55 °C
 Voltages	24V; 230V (further voltages on request)
Frequency	AC/DC
Voltage tolerance	+/- 10%
Duty cycle	100%
Electrical connection	Moulded cable (HO5RN-F3G,3x0.75 mm ²) Terminal box without safety fuse
Type of protection	IP65
Coil thermal isolation class	H
Ignition protection	II 2 G Ex d e IIC T4 bzw. T5 II 2 G Ex d e mb IIC T4 bzw. T5 II 2 D Ex tD A21 IP65 T135°C bzw. 100°C
Certificate	PTB 03 ATEX 1030 X IECEX PTB 05.0026
Safety fuse	Appropriate inrush current (see also chart recommended fusing rate)
Installation	As required, preferably with actuator upright

Cycling rate

	Max. cycling rate	Mediums temp.	Ambient temp.
Variant 1	20/min	Up to +70 °C	Up to +40 °C
Variant 2	5/min	Up to +90 °C	Up to +40 °C

Power consumption

Inrush [W]	Operation [W]
40	3

Response times

Orifice [mm]	Opening [ms]	Closing [ms]
2 - 4	30	40

Response times [ms]:

Measured at valve outlet at 6 bar and +20 °C

Opening: Pressure rise 0 to 90%,

Closing: Pressure relief 100 to 10%

Technical data (continued)

Pressure range and flow rate metal body

Circuit function	DN	Kv value water [m ³ /h]	Standard Pressure range ²³⁾ [bar]	Vacuum Pressure range [bar]
A / B / C / D / F	2.0	0.11	0 - 16	-0.98 - 10
	3.0	0.18	0 - 10	-0.98 - 6
	4.0	0.23	0 - 5	-0.98 - 3
	5.0	0.29	0 - 4	-0.98 - 2.5
E	2.0	0.11	0 - 10	-0.98 - 8
	3.0	0.18	0 - 6	-0.98 - 5
	4.0	0.23	0 - 3.5	-0.98 - 2.5
	5.0	0.29	0 - 3	-0.98 - 2
T	2.0	0.11	0 - 10	-0.98 - 8
	3.0	0.18	0 - 6	-0.98 - 5

Pressure range and flow rate for plastic body

Circuit function	DN	Kv value water [m ³ /h]	Standard Pressure range ²³⁾ [bar]	Vacuum Pressure range [bar]
A / B / C / D / F	2.0	0.13	0 - 16	-0.98 - 10
	3.0	0.25	0 - 10	-0.98 - 6
	4.0	0.30	0 - 5	-0.98 - 3
	5.0	0.40	0 - 4.5	-0.98 - 1
E / T	2.0	0.13	0 - 10	-0.98 - 7
	3.0	0.25	0 - 6	-0.98 - 5
	4.0	0.30	0 - 3	-0.98 - 2.5

¹⁾ Measured at +20 °C, 1 bar²⁾ pressure at valve inlet and free outlet.

²⁾ Devices with FKM or FFKM diaphragm are reduced to a max. pressure of 12 bar

³⁾ Pressure values [bar]: Measured as overpressure to the atmospheric pressure

Other circuit functions

The valves are fitted with different springs for a particular circuit function. When used in other circuit functions the permissible operating pressure changes acc. to the following table.

Metal body																		
Circuit function	Max. operating pressure [bar] when using the valve in a new circuit function																	
	Orifice 2 mm						Orifice 3 mm						Orifice 4 mm					
	A ¹⁾	B ¹⁾	C	D	E	F	A	B	C	D	E	F	A	B	C	D	E	F
C	16	1.5	16	1.5	1.5	16	10	1	10	1	1	10	5	0.8	5	0.8	0.8	5
D	4	16	4.5	16	4	4	2.5	10	2.5	10	2	3	2	5	2	5	2	2
T	8	8	10	10	10	8	6	6	6	6	6	6	3	3	3	3	3	3

Plastic body																		
Circuit function	Max. operating pressure [bar] when using the valve in a new circuit function																	
	Orifice 2 mm						Orifice 3 mm						Orifice 4 mm					
	A ¹⁾	B ¹⁾	C	D	E	F	A	B	C	D	E	F	A	B	C	D	E	F
C	16	1.5	16	1.5	1.5	16	10	1	10	1	1	10	5	0.8	5	0.8	0.8	5
D	4	16	4.5	16	4	4	2.5	10	2.5	10	2	3	2	5	2	5	2	2
F	16	1.5	10	1.5	1.5	16	6	1	6	1	1	10	4	1	4	1	1	

¹⁾ For circuit function A and B the valve must be connected acc. to the pin assignment of 3/2-way valve.

Additional options

Option	Variable Code	Description
Terminal box with G 1/2" or NPT 1/2" threaded nipple	JA09 respectively, JA10	Instead of the cable gland a threaded nipple with internal thread is installed in the terminal box. Thereby laying the cable in a closed steel pipe system is possible.
Oxygen versions	NL02	Suitable for applications with oxygen (non-metal materials that are in contact with the medium, are tested and approved according to BAM)
Increased purity requirements e.g. oil, grease and silicone-free	NL50/NL05	Wetted parts are specially cleaned and packaged in accordance with the valves
Increased hermetic requirements	PCxx	Standard units are tested at 10 ⁻² mbar x l / sec; feasible up to 10 ⁻⁶ mbar
Vacuum version	NA02	Suitable for vacuums up to -0.98bar
Increased purity and hermetic requirements	NA03	Wetted parts are specially cleaned and leak tested to 10 ⁻⁴ mbar x l/sec
Increased purity and hermetic requirements and vacuum version	NA01	Wetted parts are specially cleaned and leak tested up to 10 ⁻⁴ mbar x l / sec and suited for vacuum up to -0.98 bar
Electrical feedback	CF15	Coil with intrinsically safe proximity switches (PTB 00 ATEX 2048X) instead of manual override
Manifold with banjo bolt	LG09	Due to the banjo bolt a direct attachment is possible (for example, to externally controlled pneumatic drives)
potential conformities (depending on design)		EAC ; drinking water; FDA;

Dimensions [mm]

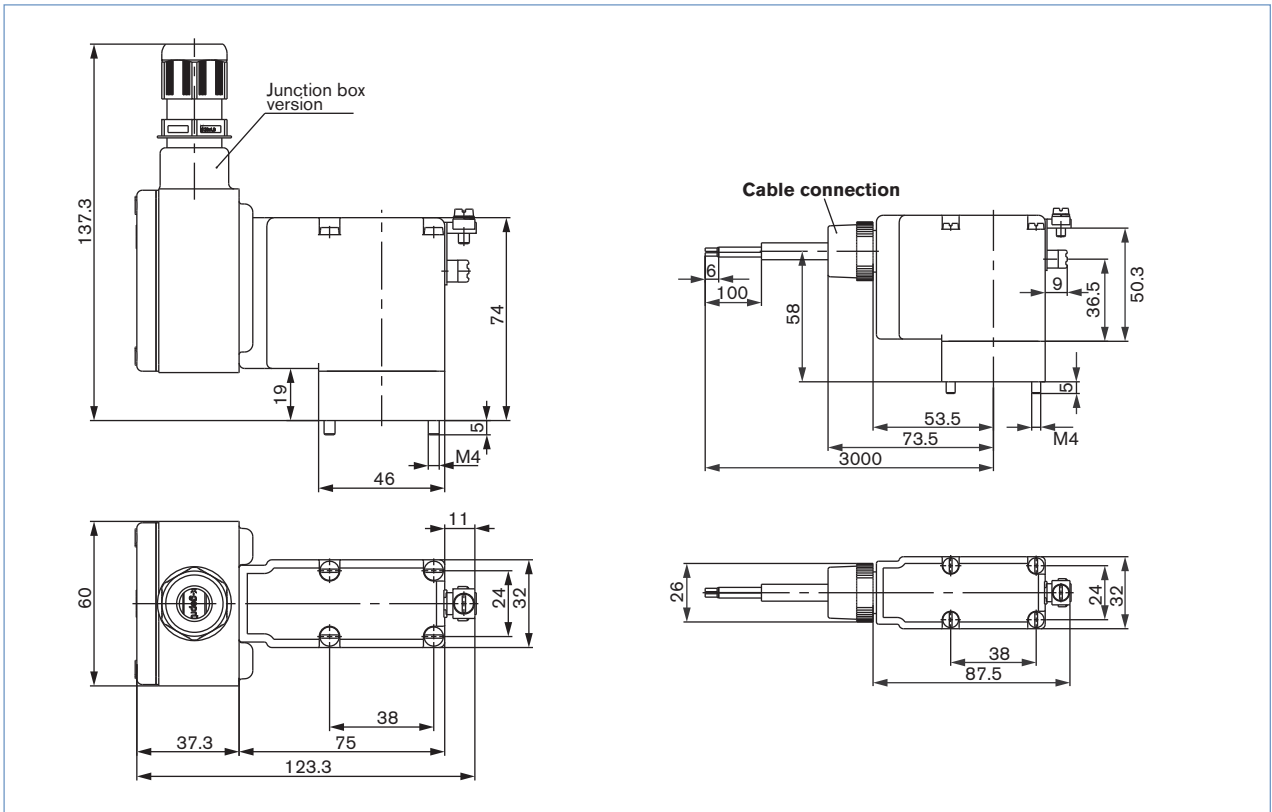

PIN Assignments

The connections marked with 1, 2 and 3 are labelled in the drawing according to the circuit function table on the left.

Circuit function	Connection 1	Connection 2	Connection 3
A	P	A	
B	B	P	
C	P	A	R
D	R	B	P
E	P1	A	P2
F	A	P	B

Recommended fusing rate

Voltage [V]	Max. current [A]
24	2
230	0.5
110 resp. 120	0.8

Ordering chart – selection table (articles with reduced delivery time)

All devices with manual override

Circuit function	Orifice [mm]	Seal Material	Housing or seat material	Electrical connection	Item no. per voltage/frequency [V/Hz]		
					024/UC	110/UC	230 resp. 240 /UC
A	03.0	FKM	Stainless steel	Cable	145 702	–	143 730
C	02.0	NBR	Stainless steel	Terminal box	–	153 748	–
C	02.0	FKM	Stainless steel	Terminal box	–	137 604	–
C	02.0	NBR	Stainless steel	Cable	141 687	–	–
C	02.0	FKM	Brass	Terminal box	–	–	142 705
C	03.0	NBR	Brass	Cable	–	–	088 747
C	03.0	NBR	Brass	Terminal box	–	140 105	–
C	03.0	FKM	Stainless steel	Cable	145 703	–	–
D	02.0	NBR	Brass	Terminal box	–	136 704	137 983
D	02.0	NBR	Brass	Cable	–	–	138 151
D	02.0	NBR	Stainless steel	Cable	138 365	–	132 080
D	02.0	NBR	Stainless steel	Terminal box	–	153 747	160 701
D	03.0	NBR	Brass	Cable	140 579	–	–
F	04.0	FKM	Brass	Terminal box	–	–	132 435
T	02.0	FKM	Stainless steel	Cable	138 264	–	137 899
T	02.0	FKM	Stainless steel	Terminal box	–	138 267	138 268
T	02.0	NBR	Stainless steel	Cable	138 258	–	–
T	02.0	EPDM	Stainless steel	Terminal box	–	–	148 146
T	02.0	NBR	Brass	Cable	138 246	–	138 248
T	02.0	NBR	Brass	Terminal box	–	138 250	138 251
T	02.0	FKM	Brass	Cable	138 252	–	138 254
T	02.0	FKM	Brass	Terminal box	–	138 256	138 257
T	03.0	FKM	Stainless steel	Terminal box	–	157 201	157 202
T	03.0	FKM	Brass	Terminal box	–	157 204	157 205

To find your nearest Bürkert facility, click on the orange box →

www.burkert.comIn case of special application conditions,
please consult for advice.Subject to alterations
© Christian Bürkert GmbH & Co. KG

1604/10_EU-en_00891625